

# EVERGLADE™ LITTER BIN

 Operator Instruction Leaflet

IMPORTANT NOTE: ENSURE THAT ALL RELEVANT PERSONNEL READ THESE INSTRUCTIONS PRIOR TO USE

## To Remove and Replace Locking Liner

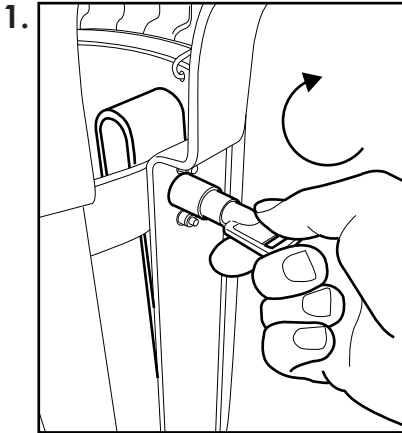

Insert Key and twist clockwise to unlock.

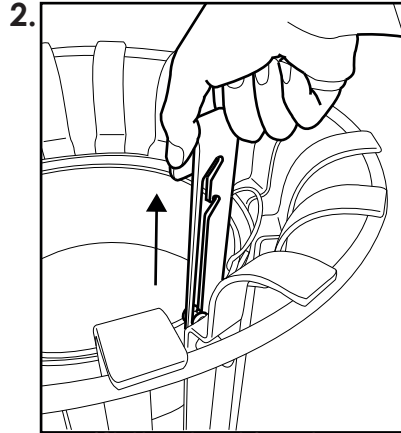

Lift the locking bar upwards - the location slot will guide its movement.

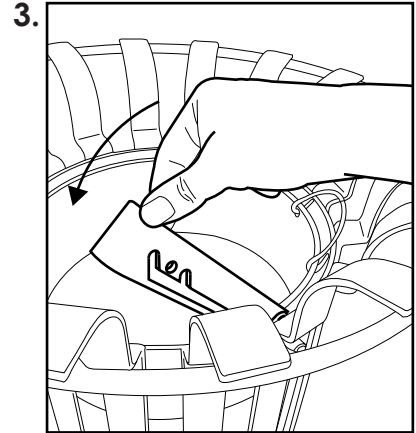

Push the Locking bar across into its unlocked resting position.

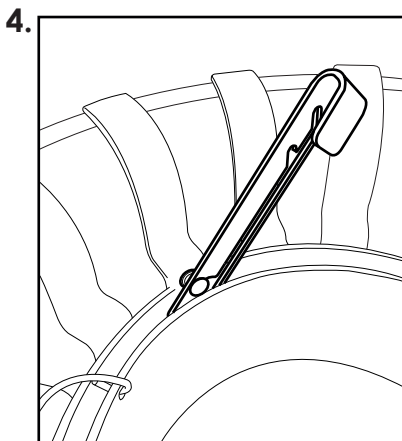

In this resting position, the Locking bar does not foul the vertical movement of the Liner.

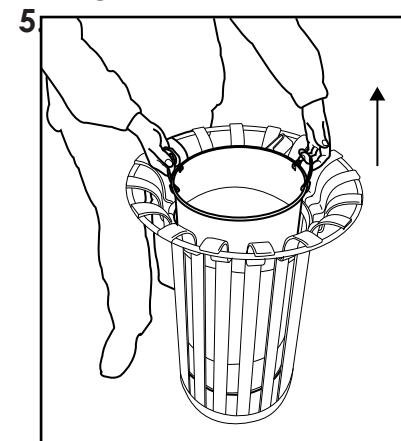

Lift the Liner from the bin using the handles on the Liner rim.

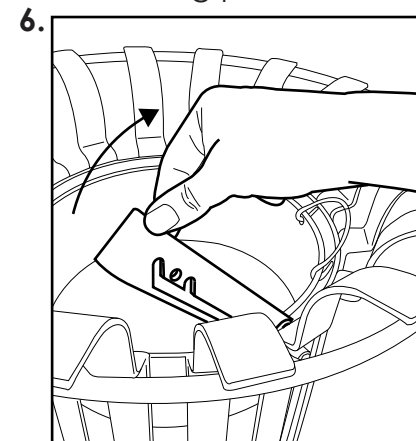

Upon replacement of the Liner, pull the Locking bar across from its resting position.

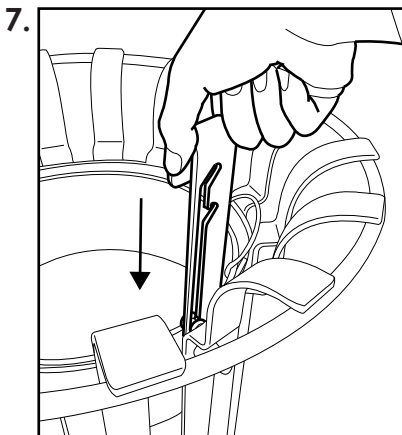

Allow the Locking bar to drop back down into its locking position.

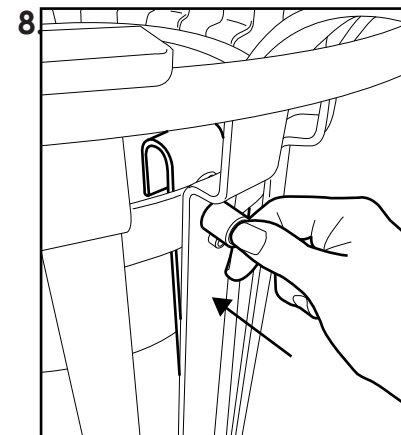

Push the Lock back into the barrel to secure the Locking bar in position, and Liner in the bin.

# EVERGLADE™ LITTER BIN



## To Secure a Sack in Position (Open Top or Dome Top Model)

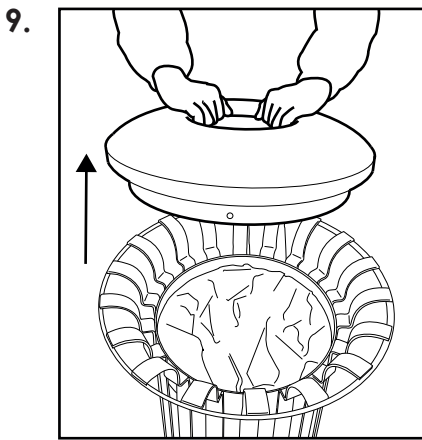

Remove Dome Top

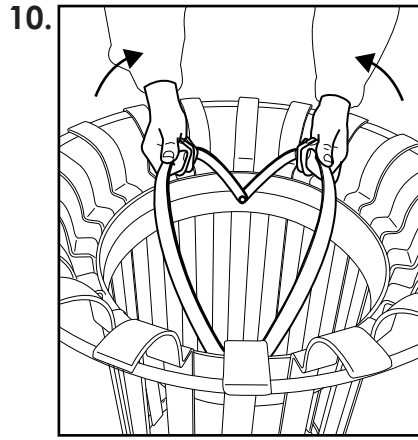

Pull the sack bands upwards.

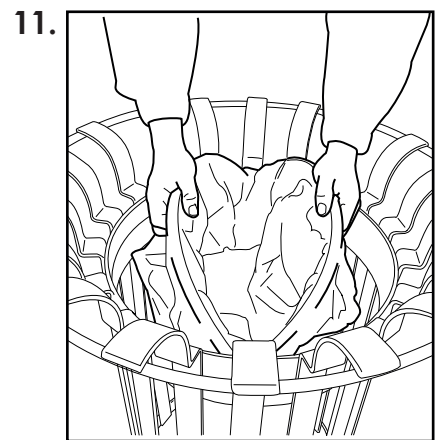

Pull the sack up from within the bin and wrap over the sack bands.

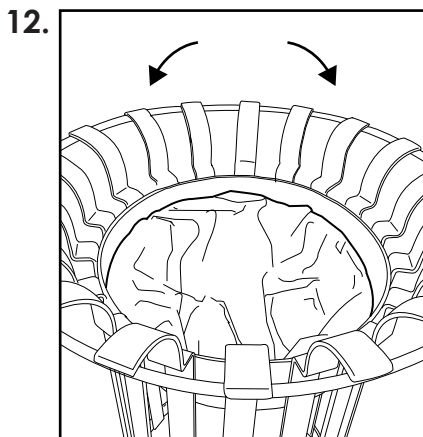

Push the sack bands back down to secure the sack in position.

## To Install Pedastal

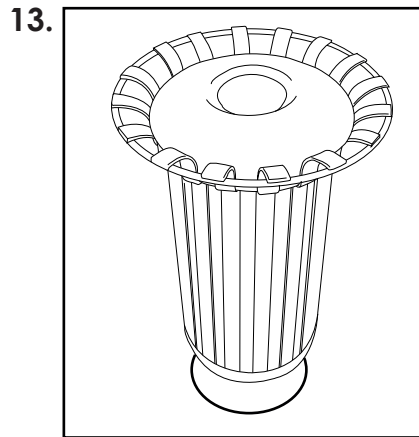

Attach pedastal to bin using the M10 x 30 bolts and Nyloc nuts provided. **Note:** Follow separate installation instructions provided with ground fixing kit.

# EVERGLADE™ LITTER BIN



## Instructions For Concrete/Paving Fixing Kit



Ensure that personnel carrying out this installation have the relevant qualifications/certificates.

Ensure that all relevant personnel read the points listed within this leaflet and that a copy is given to staff involved with the installation and maintenance of this product. Please refer to 'The Manual Handling Operations Regulations 1992'.

Glasdon recommends that a full Health and Safety analysis is carried out prior to installation.

**Note: Always check thoroughly for buried services**

### KIT CONTENTS

- 4 Ground Bolts

### EQUIPMENT REQUIRED

- Drill
- 12mm Masonry Drill Bit
- 17mm Socket Wrench/Spanner
- Hammer

1. Place bin in the desired position onto a prepared concrete foundation or concrete paving.
2. Ensure there is a minimum distance of 110mm from the centre of the intended fixing point and the edge of the foundation/slab.
3. Mark the four outer hole positions from the inside of the bin.
4. Remove the bin and drill the marked holes with a 12mm masonry drill bit to a minimum depth of 80mm, or through the paving slab.
5. Ensure the holes are free from any obstructions and debris caused by drilling.
6. Reposition bin so that the holes in the bin and the drilled holes are aligned, then insert all four Ground Bolts.
7. Ensure the washer is in position at the top of the Bolt and tap down all fixings using a hammer.
8. Tighten up all the Bolts using a 17mm socket wrench/spanner until tight and the bin is secured soundly (maximum recommended torque setting is 40Nm).

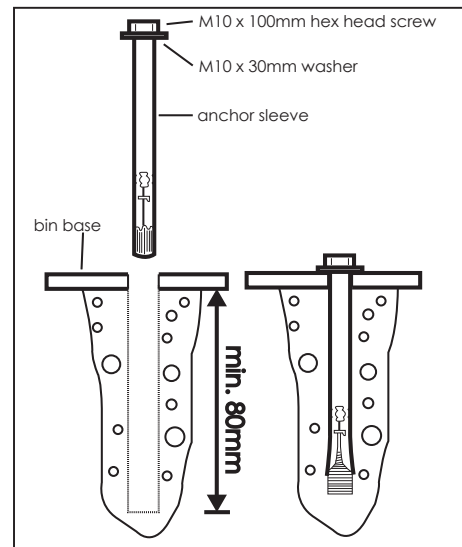

 **Glasdon** AND EVERGLADE ARE TRADEMARKS OF GLASDON GROUP OR ITS SUBSIDIARIES IN THE U.K. AND OTHER COUNTRIES

- A planned maintenance schedule of regular inspection is recommended, replacing components as necessary.
- Replacement components are available direct from GLASDON UK LIMITED.
- GLASDON UK LIMITED cannot be held responsible for claims arising from incorrect installation, unauthorised modifications or misuse of the product.

Issue 2 November 2014 C000/0436  
© Copyright 2014 07B344-39  
Glasdon UK Ltd reserve the right to alter specifications without prior notice.



**Glasdon**

Glasdon U.K. Limited

Preston New Road  
BLACKPOOL  
Lancashire FY4 4UL  
Tel: 01253 600410  
Fax: 01253 792558  
email: sales@glasdon-uk.co.uk  
web: www.glasdon.com